

Softwood Bench

English SS342A

Help Line (Normal Office Hours): 01829 261 121
 Email: support@rowgar.co.uk Website: www.rowgar.co.uk

Assembly Instructions

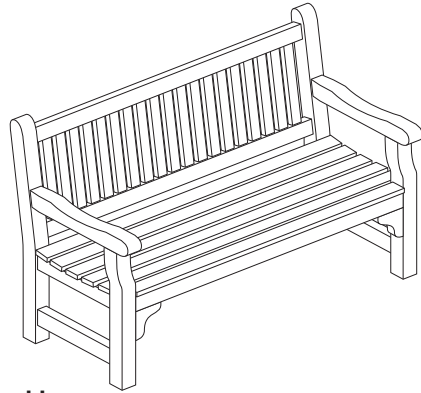

Before assembly

- We recommend that time is taken to read the instructions before starting assembly, then follow the easy step by step guide. The instruction sheet is only a guide to the assembly. Certain items may not be shown to scale.
- Check all components prior to assembly
- This product should be assembled by no less than two people.
- Never attempt to erect the assembly in high winds.
- It may be necessary to drill pilot holes for some screws.

Biocidal Products Regulation EU 528/2012
 Wolmanit[®] CX treated wood is a treated article that incorporates biocidal products: copper hydroxide carbonate/II and boric acid. They protect wood against fungal decay/rot/ and insect attack.
 Keep away from food, drink and animal feeding stuffs. Avoid breathing dust when cutting treated wood.



Recommended tools for assembly

- Allen key (supplied in kit)
- Power screwdriver
- Cross head screwdriver bit
- Flat blade screwdriver

No.	Components	Qty.
1	Leg	2
2	Seat	1
3	Front rail	1
4	Back rail	1
5	Seat back	1
6	Corner braces	2

No.	Components	Qty.
7	100mm bolt	6
8	Barrel nut	6
9	70mm screw	8
10	60mm screw	4
11	45mm screw	8
12	Allen key	1

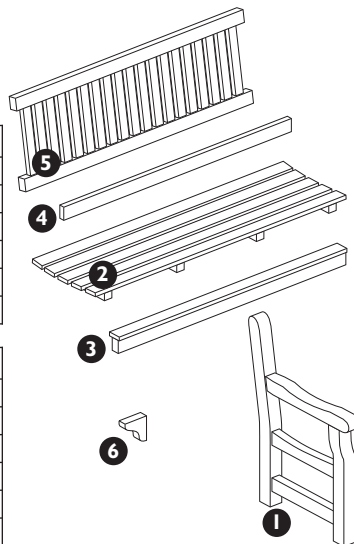

1. Seat

Attach the front rail to the front of the seat as shown using 4 x 60mm screws. Attach the back rail to the back of the seat, secure through the back rail into the seat frame using 4 x 45mm screws then secure down through the rear seat slat into the back rail using 4 x 45mm screws.

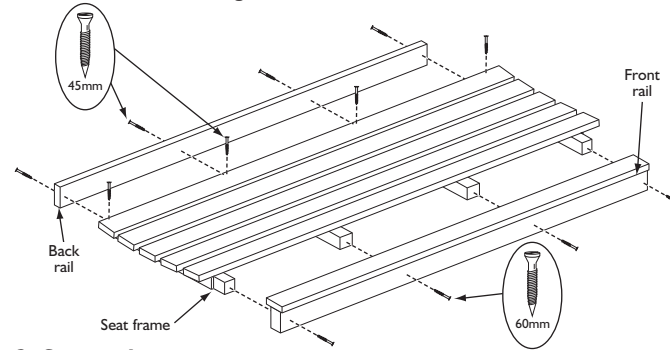

2. Seat to legs

Position the seat between the legs. From underneath the seat secure together using 2 x 70mm screws each side, screw through the seat frame into the seat support of the legs. Insert a barrel nut into each hole on the back of the front rail. Push a bolt through the drilled hole on the sides of each front leg and screw into the barrel nuts.

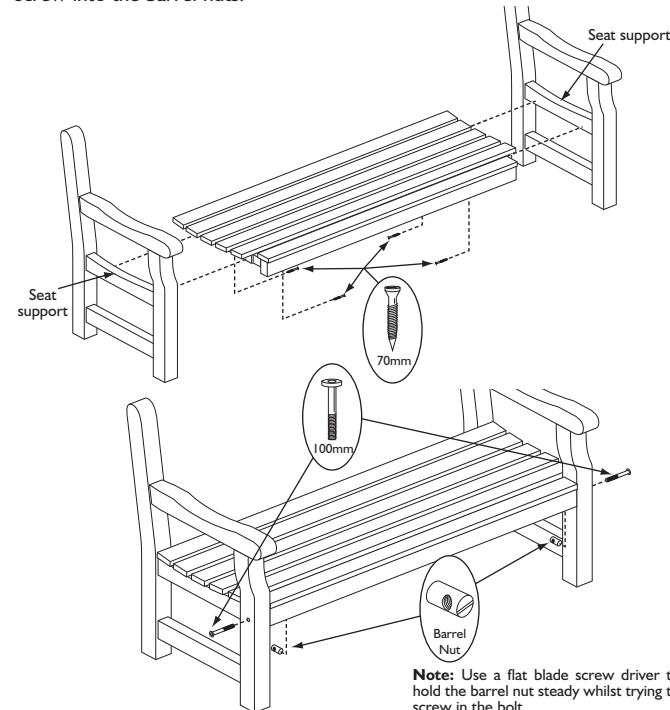

3. Seat back

Position the seat back between the legs. Push a barrel nut into each of the four holes in the back of the seat back. Push a bolt through the drilled holes on the sides of each back leg and screw into the barrel nuts.

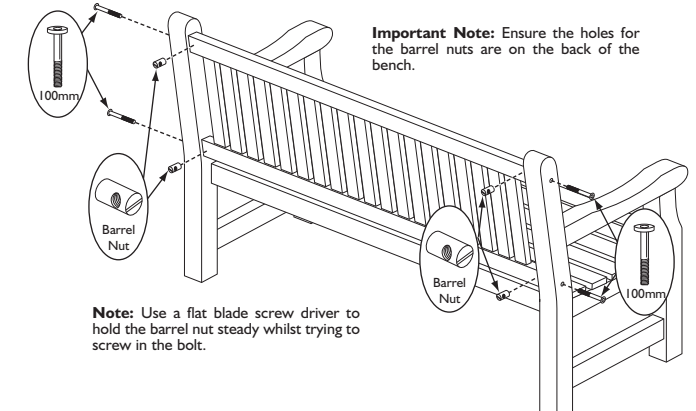

Important Note: Ensure the holes for the barrel nuts are on the back of the bench.

Note: Use a flat blade screw driver to hold the barrel nut steady whilst trying to screw in the bolt.

4. Corner braces

Attach the corner braces between the underside of the front rail and front legs as shown. Secure in place through the pre-drilled holes using 2 x 70mm screws per brace.

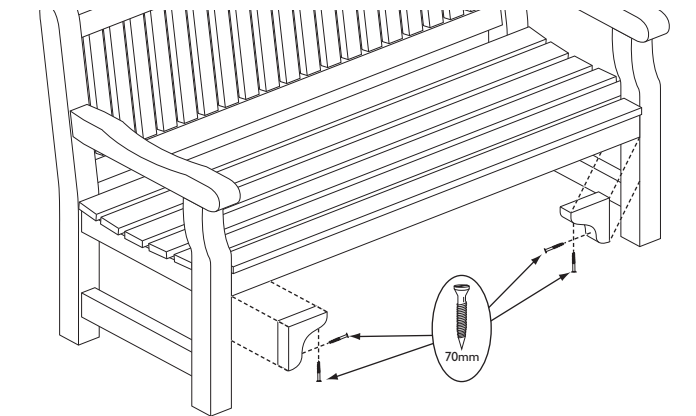

**IMPORTANT: RETAIN FOR FUTURE REFERENCE
 READ CAREFULLY**

Periodically check all fastenings for tightness
 For contract and domestic use

We constantly improve the quality of our products, occasionally the components may differ from the components shown and are only correct at time of printing. We reserve the right to change the specification of our products without prior notice.

2015 © Rowlinson Garden Products Ltd